

# HINO 198 SERIES



# 2012

## TRUCK CHASSIS SPECIFICATIONS

**(NE8J) SS-NE028AHB7**  
**GVW: 8,845 kg (19,500 lbs.)**

All 2012 models require ultra-low sulfur diesel fuel

### DIMENSIONS (On standard specifications)

MODEL		NE8JGSA-HB7	NE8JJA-HB7	NE8JLSA-HB7	NE8JMSA-HB7
Wheelbase	A mm(in.)	3,861 (152.0)	4,445 (175.0)	4,750 (187.0)	5,207 (205.0)
Overall length	B mm(in.)	6,162 (242.6)	7,076 (278.6)	7,686 (302.6)	8,143 (320.6)
Overall width	C mm(in.)	2,430 (95.7)	2,430 (95.7)	2,430 (95.7)	2,430 (95.7)
Overall height	D mm(in.)	2,610 (102.8)	2,610 (102.8)	2,610 (102.8)	2,610 (102.8)
Cab to axle	E mm(in.)	2,149 (84.6)	2,733 (107.6)	3,038 (119.6)	3,495 (137.6)
Rear overhang	F mm(in.)	1,270 (50.0)	1,600 (63.0)	1,905 (75.0)	1,905 (75.0)
Frame height at					
Front axle	G mm(in.)	830 (32.7)	830 (32.7)	830 (32.7)	830 (32.7)
Rear axle	H mm(in.)	910 (35.8)	910 (35.8)	910 (35.8)	910 (35.8)
Road clearance					
(at front axle)	J mm(in.)	180 (7.1)	180 (7.1)	180 (7.1)	180 (7.1)
Tread					
Front	K mm(in.)	2,020 (79.5)	2,020 (79.5)	2,020 (79.5)	2,020 (79.5)
Rear	L mm(in.)	1,840 (72.4)	1,840 (72.4)	1,840 (72.4)	1,840 (72.4)
Turning radius					
Tire	mm(in.)	6,460 (254.3)	7,320 (288.2)	7,760 (305.5)	8,430 (331.9)
Swept	mm(in.)	6,970 (274.4)	7,830 (308.3)	8,270 (325.6)	8,940 (352.0)

### CHASSIS WEIGHTS (On std. spec., without spare tire & std. tool set)

AT	Total weight	kg(lb.)	4,300 (9,400)	4,275 (9,440)	4,350 (9,580)	4,350 (9,640)
	Front axle	kg(lb.)	2,635 (5,734)	2,710 (5,947)	2,735 (6,035)	2,785 (6,169)
	Rear axle	kg(lb.)	1,665 (3,666)	1,565 (3,493)	1,570 (3,545)	1,565 (3,471)

### POWER LINE & PERFORMANCE

[8,863 kg (19,500 lbs.) GVW & 225/70/R19.5 tires]

Power line	□ OPT.
Max. speed km/h	135
Gradeability (tan.θ) %	31.9
Transmission Model	Allison 1000 RDS
Type	Six-speed automatic
1st.	3.102
2nd.	1.811
3rd.	1.406
Ratios	4th. 1.000
	5th. 0.712
	6th. 0.610
	Rev. 4.492
Rear axle gear ratios	4.110
Tire size	225/70R19.5

### ENGINE

Model	HINO J08E-VC
Type:	Diesel, 6 cylinder, in-line, water-cooled
Combustion system:	Direct injection type
Max. output: (SAE Gross)	220HP at 2,500 rpm
Max. torque: (SAE Gross)	706 N·m (520 lb.-ft.) at 1,500 rpm
Bore and stroke:	112 x 130 mm (4.41 x 5.12 in.)
Piston displacement	7.684 L (468.8 cu.in.)
Fuel injection system:	Common rail ND
Governor:	Electronically controlled
Intake system:	Turbocharged and intercooled
Air cleaner:	Paper filter type ("DONALDSON")
Pre-heater:	Glow plug type
Fan clutch:	Bimetal thermostat sensor regulates fan speed
Block heater:	1,000 watts/120V immersion type

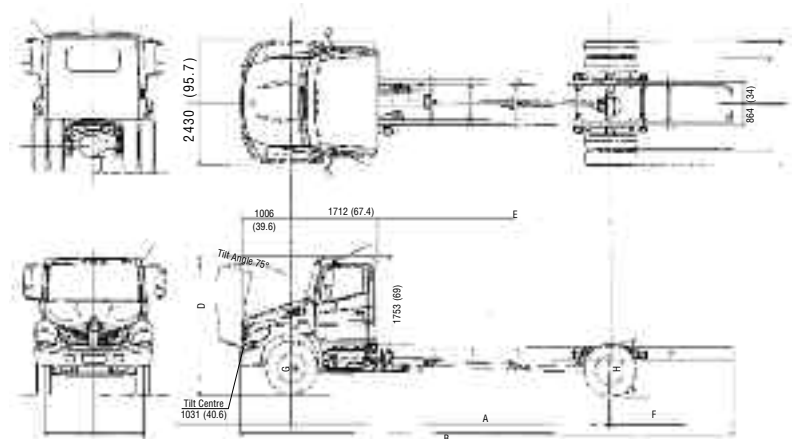

THE QUALITY CHOICE.  
[www.hinocanada.com](http://www.hinocanada.com)

**WEIGHT CAPACITIES**

Front axle	kg (lbs.)	3,309 (7,280)
Rear axle	kg (lbs.)	6,209 (13,660)
Front spring	kg (lbs.)	3,636 (8,000)
Rear spring	kg (lbs.)	8,636 (19,000)

**LIQUID CAPACITIES**

Fuel tank ltr.(gal./US)	196.8 (52), aluminum
Cooling system	Allison 1000 RDS:
ltr.(gal./US)	23.0 (6.08)
Diesel Exhaust Fluid, ltr. (gal.US)	19 (5.02)

**AXLE / SUSPENSION**

Front axle	MFS-8 series reversed Elliot, "I" beam, Oil lubricated front wheel bearings
Front spring	Taper-leaf springs w/ shock absorbers
Rear axle	RS17-145 series Full-floating, single reduction Single-speed hypoid gears, oil-lubricated type
Rear spring	Semi-elliptic main and auxiliary helper
Option:	Two air bag suspension with shock absorbers and dump valve

**FRAME**

Ladder type	Straight J section
Width mm(in.)	863.6 (34)
Tensile strength kg/mm <sup>2</sup> (lb/in) <sup>2</sup>	63.4 (90,143)
Resisting bending moment (one side)	1,188,862 (1,031,900) no reinforcement
kgf•cm (in•lbs.)	

**STEERING**

Type	Telescopic and tilt steering column with lock Recirculating ball, with hydraulic booster integral type
------	--

**WHEELS / TIRES**

6 Wheels	19.5X6.75 8-stud disc.
6 Tires	225/70R19.5(G)
Brand & Pattern	BS Fr: RIB, Rr: LUG

**BRAKES**

Service brake	Hydraulic system with disc brakes for front and rear wheels, with automatic adjustment
Disc diameter	Front;
x pad area (cm <sup>2</sup> )	390.5 x 122.3 x 18.8
x thickness	(15.375 x 18.96 x 0.74)
mm(in.)	Rear;
	390.5 x 122.3 x 18.8
	(15.375 x 18.96 x 0.74)
Control	Hydraulic dual circuit with Antilock Brake System (ABS)
Parking brake	Mechanical, internal expanding acting on the drive shaft
Drum diameter	304.8 (12)
mm(in.)	
Exhaust brake	Electric-pneumatic with valve in exhaust pipe

**CAB EQUIPMENT**

Cab construction	- All steel welded
Seating	- Three
Driver's seat	- Adjustable reclining, covered with fabric, with air suspension and armrest
Passenger's seat	- Bench type, covered with fabric
Seat belts	- 3-point type (driver and passenger), one 2-point type (centre)
Heater/Defroster	- 18,357 BTU/h (4,627 Kcal/h)
Power mirrors	- outside rearview, black, 1 flat, heated and 1 convex on each side
Sun visors	- Two
Over-head console	- Two
Air conditioning	
Windshield	- Laminated
Windshield wipers	- Dual electric, 2-speed and intermittent
Cup holders	
Electric power windows	
Electronic cruise control	
Cigarette lighter / 12V power outlet	
Power door locks	- keyless entry

**DASH INSTRUMENTATION**

Driver information display	
Meters and gauges, metric system	
Speedometer	- km/h (mph)
Odometer	(km/h)
Fuel gauge	
Diesel exhaust fluid gauge	
Coolant temperature gauge	
Engine tachometer	
Warning and pilot lamps and buzzers	
Oil pressure warning lamp and buzzer	
Coolant level warning lamp and buzzer	
Battery charging warning lamp	
High beam indicator lamp	
Turn signal pilot lamp	
Parking brake warning lamp	
Engine control system warning lamp	
ABS warning lamp	
Glow plug pre-heater indicator lamp	

**ELECTRICAL EQUIPMENT**

Batteries	Two, parallel connection, each 12 V
Capacity	1400 CCA
Alternator	12 V, 135 A brushless
Starter	12 V, 4.0 kW
Audio system	AM/FM radio with CD, DVD, GPS & Bluetooth®
Headlamps	2, composite type
Identification lamps (front)	LED type
Stop/Tail lamps	
Back-up lamps	
Turn signals and hazard warning lamps	
Dome lamps	
Front side marker lamps	
Clearance lamps (front)	LED type
Electrical horn (dual)	

**CHASSIS EQUIPMENT**

Fuel pre-filter	- Pre-filter (dust) and sedimenter (water) with heater, Davco
Reflectors	- Two rear, two front side
Hook	- One at front
Radiator Grille	- painted, silver
Bumper	- white, 3 piece

*See your authorized Hino Dealer for a complete list of options and accessories.*

**NOTE :** All specifications of the products are with normal manufacturing allowances and tolerances.

HINO MOTORS CANADA, LTD. reserves the right to alter specifications at any time without previous notice.